

STANDARD CAMERA MOUNT

- (1) 1/2-13 BOLT
- (1) 1/2 FLAT WASHER
- (1) 1/2 SPLIT LOCK WASHER
- (1) 1/2 HEX NUT

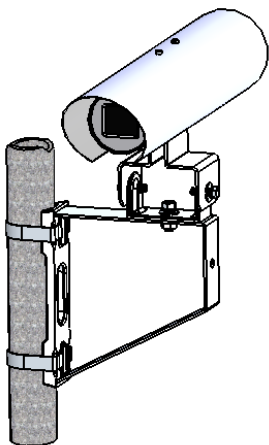
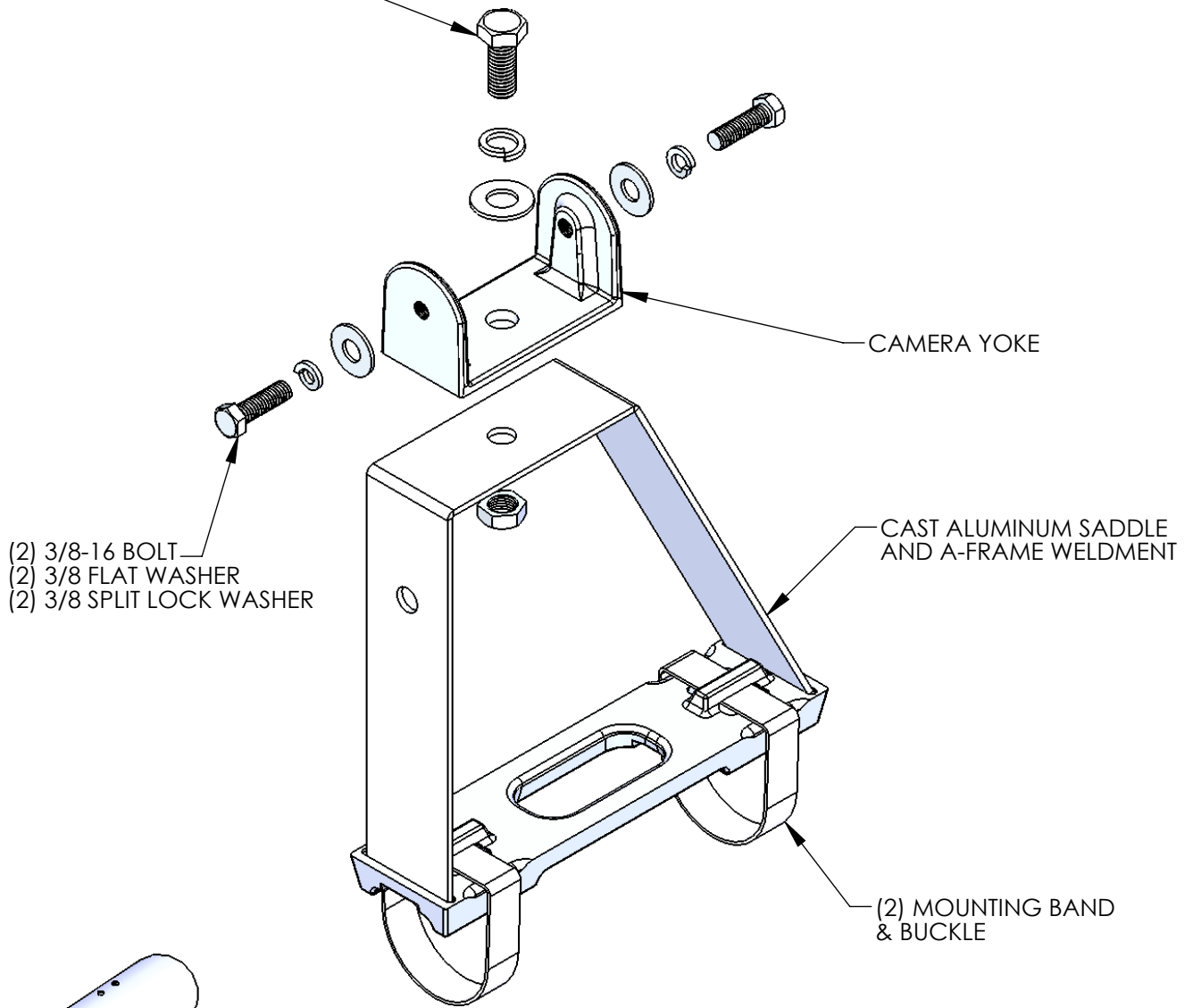

ALTERNATE MOUNTING

TORQUE CHART	
FASTENER SIZE	TORQUE
5/16"	10 FT-LBS
3/8"	15 FT-LBS
1/2"	15 FT-LBS

## **Installation Instructions**

### **Standard Camera Mount**

#### **Preparation:**

Read and understand these instructions prior to beginning.

Review installation instructions provided by camera manufacturer. Verify mounting location and method is acceptable.

Check parts against the installation drawing accompanying these instructions, verify all necessary components are present and undamaged.

Review tools required to perform the installation, ensure all tools are present and in good working order prior to beginning the installation process.

Safety first! Review and adhere to all applicable work zone safety information to ensure installer safety.

#### **Installation:**

Determine mounting location - When determining the mounting location careful thought must be given to ensure access to tensioning components, adjustment screws and electrical connections.

Mount bracket weldment – With bracket in desired position, tighten banding with an approved banding tool (information may be found at [www.band-it-idex.com](http://www.band-it-idex.com)). Banding must be tight enough to ensure mounting bracket does not shift or slip under load.

Trim bands – Cut off excess banding material, use caution as trimmed edges of banding may be sharp after trimming.

Attach camera yoke – Bolt camera yoke to mounting bracket weldment with the supplied ½” hardware *hand tighten* only.

Mount camera – Attach camera to camera yoke with the supplied 3/8” hardware *hand tighten* only.

Aim camera – Follow camera manufacturer’s instructions for proper aiming of the camera.

Tighten mounting hardware – after aiming the camera securely tighten all fasteners. 3/8” hardware to be torqued to 15 ft lbs, ½” hardware to be torqued to 20 ft lbs.

#### **Inspection:**

Review installation – Verify all hardware is tightened to proper specifications and banding is sufficiently tight to prevent movement.

Camera view – Verify camera is aimed properly, camera may be readjusted by loosening threaded hardware as required. Retighten hardware if adjustments are required.