

RIGID CAMERA MOUNT - CABLE STYLE

- (1) 1/2-13 BOLT
- (1) 1/2 FLAT WASHER
- (1) 1/2 SPLIT LOCK WASHER

- (2) 3/8-16 BOLT
- (2) 3/8 FLAT WASHER
- (2) 3/8 SPLIT LOCK WASHER

- (2) 3/8-16 BOLT
- (2) 3/8 FLAT WASHER
- (2) 3/8 SPLIT LOCK WASHER

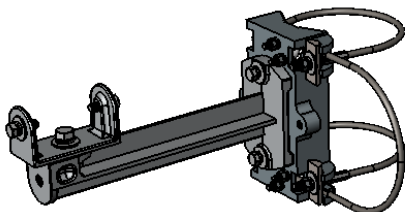
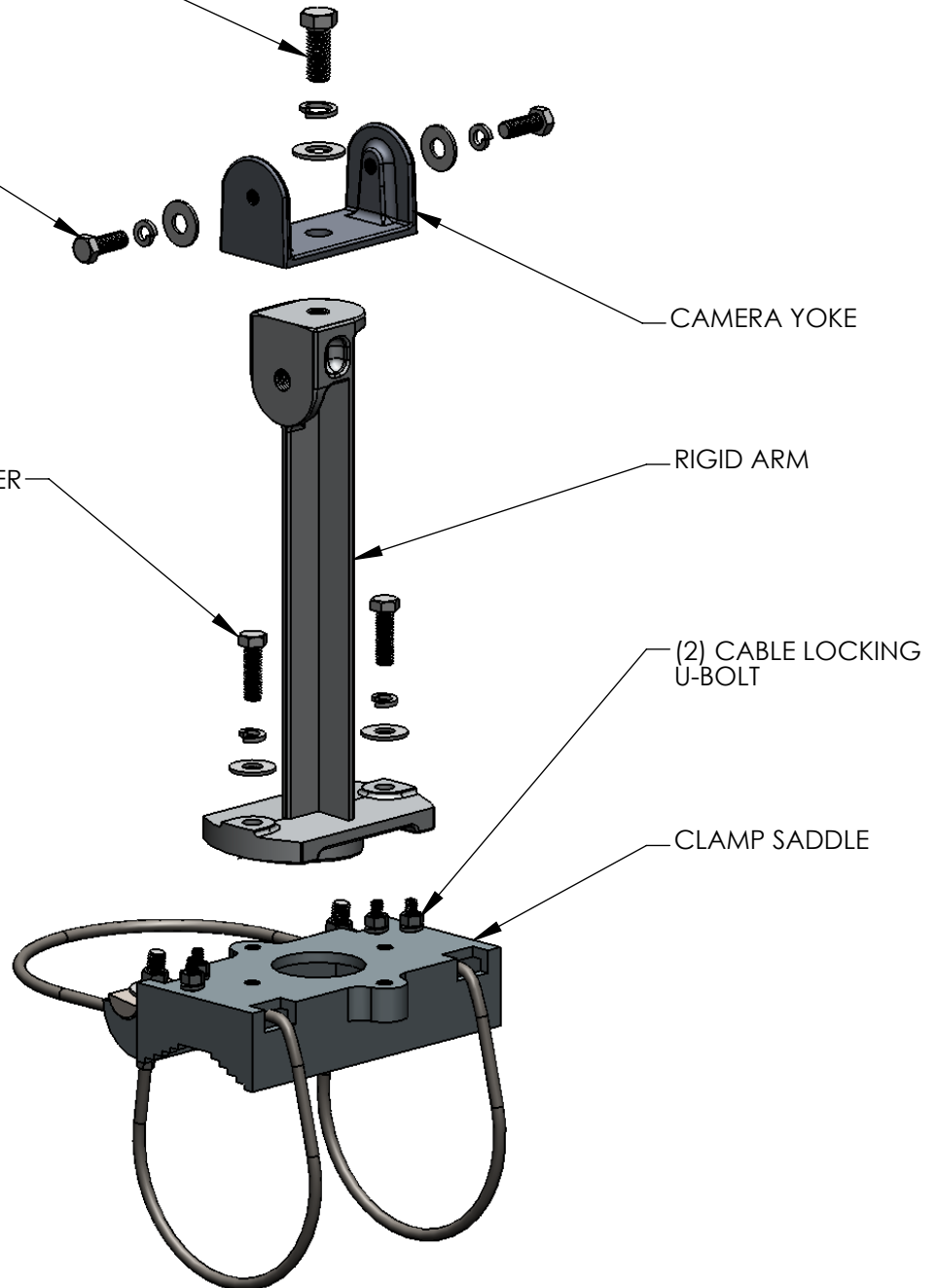

ALTERNATE MOUNTING

TORQUE CHART	
FASTENER SIZE	TORQUE
5/16"	10 FT-LBS
3/8"	15 FT-LBS
1/2"	15 FT-LBS

Installation Instructions

Rigid Camera Mount – Cable Style

Preparation:

Read and understand these instructions prior to beginning.

Review installation instructions provided by camera manufacturer. Verify mounting location and method is acceptable.

Check parts against the installation drawing accompanying these instructions, verify all necessary components are present and undamaged.

Review tools required to perform the installation, ensure all tools are present and in good working order prior to beginning the installation process.

Safety first! Review and adhere to all applicable work zone safety information to ensure installer safety.

Installation:

Determine mounting location - When determining the mounting location careful thought must be given to ensure access to tensioning components, adjustment screws and electrical connections.

Mount saddle bracket – Position saddle on mast arm with cable loop on top. While holding saddle in position route loose cable ends under mast arm and place cable stops in cradles on saddle. Take care to ensure cable is laying in groove in cradles. Pull up on the “loop” to remove all slack. Tighten 2 cable locking u-bolts. Adjust position of saddle if required. Tighten cables while keeping studs on cable from turning. Cable must be tight enough to ensure mounting bracket does not shift or slip under load.

Secure excess cable – Excess cable may be secured to the mast arm/clamp by plastic ties or other methods. (Not supplied)

Mount rigid arm casting – Bolt rigid arm to saddle casting in desired orientation with supplied 3/8” hardware *hand tighten* only.

Attach camera yoke – Bolt camera yoke to rigid arm casting with the supplied 1/2” hardware *hand tighten* only.

Mount camera – Attach camera to camera yoke with the supplied 3/8” hardware *hand tighten* only.

Aim camera – Follow camera manufacturer’s instructions for proper aiming of the camera.

Tighten mounting hardware – After aiming the camera securely tighten all fasteners. 3/8” hardware to be torqued to 15 ft lbs, 1/2” hardware to be torqued to 20 ft lbs.

Inspection:

Review installation – Verify all hardware is tightened to proper specifications and cable is sufficiently tight to prevent movement.

Camera view – Verify camera is aimed properly, camera may be readjusted by loosening threaded hardware as required. Retighten hardware if adjustments are required.