

SKYBRACKET

MAST ARM MOUNTING HARDWARE

(815) 229-3292
 F: (815) 229-7082
 2135 15th St. Box 6106
 Rockford, IL 61125

www.SkyBracket.com

STANDARD TRAFFIC SIGNAL MOUNTING - BAND STYLE

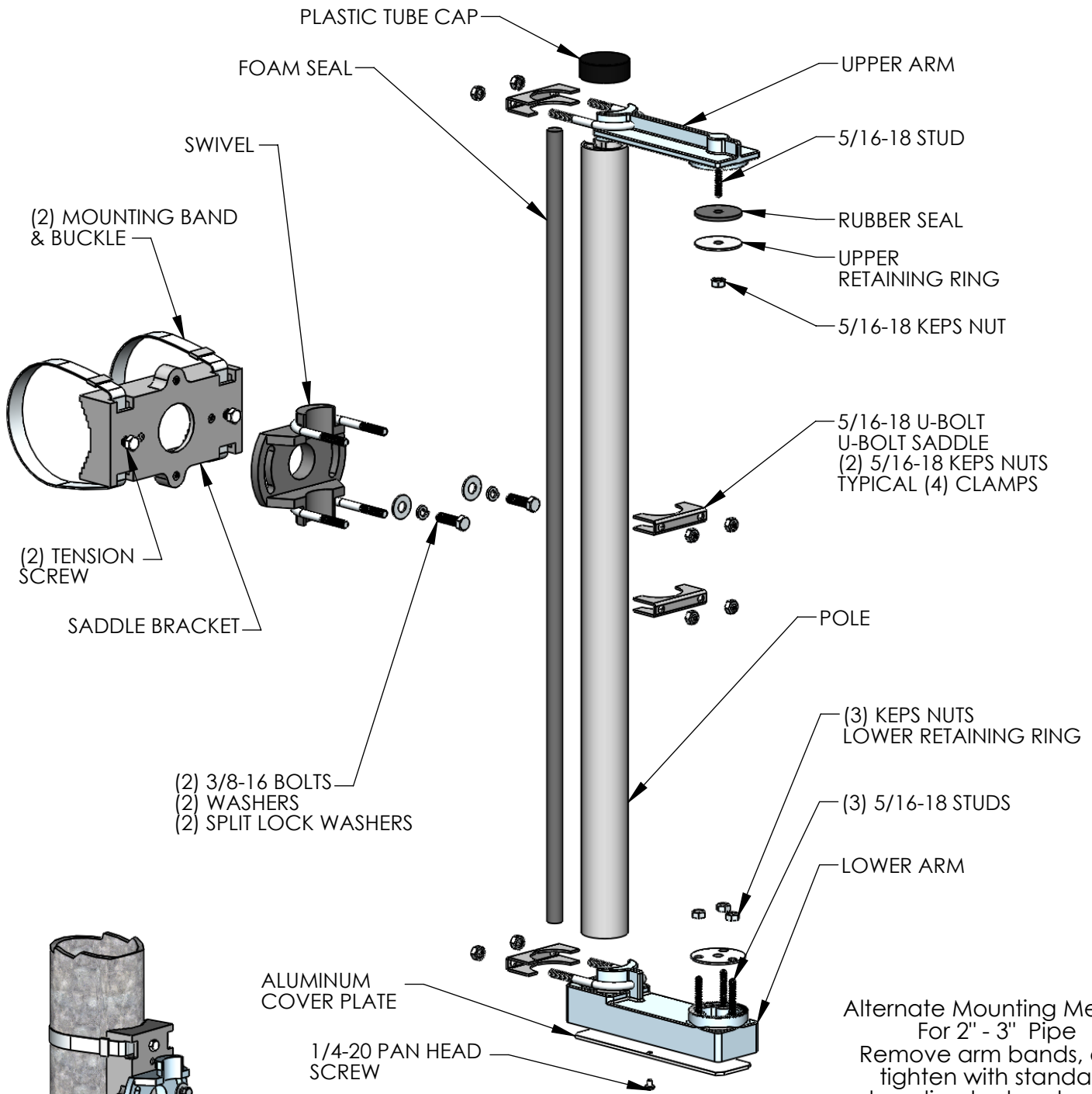

Alternate Mounting Method
 For 2" - 3" Pipe
 Remove arm bands,
 and tighten with standard
 banding tool as shown.

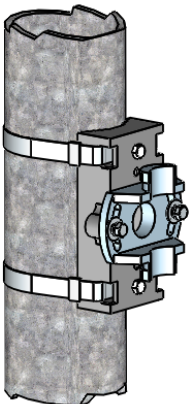

ALTERNATE MOUNTING

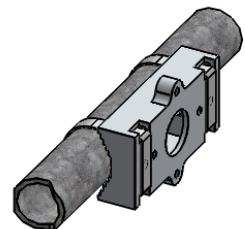

TORQUE CHART	
FASTENER SIZE	TORQUE
5/16"	10 FT-LBS
3/8"	15 FT-LBS
1/2"	15 FT-LBS

Installation Instructions

Standard Traffic Signal Mount – Band Style

Preparation:

Read and understand these instructions prior to beginning.

Review installation instructions provided by signal manufacturer. Verify mounting location and method is acceptable.

Check parts against the installation drawing accompanying these instructions, verify all necessary components are present and undamaged.

Review tools required to perform the installation, ensure all tools are present and in good working order prior to beginning the installation process.

Safety first! Review and adhere to all applicable work zone safety information to ensure installer safety.

Installation:

Determine mounting location - When determining the mounting location careful thought must be given to ensure access to tensioning components, adjustment screws and electrical connections.

Mount saddle bracket – With bracket in desired position, tighten banding with an approved banding tool (information may be found at www.band-it-idex.com). Tighten until bands prevent clamp weight from repositioning the assembly. Tighten the 2 pressure screws as needed to add additional tension to banding. Banding must be tight enough to ensure mounting bracket does not shift or slip under load.

Trim bands – Cut off excess banding material, use caution as trimmed edges of banding may be sharp after trimming.

Install lower arm – Insert on end of tube with the slot aligned with tab located in the bottom of the lower arm, making certain the tube is resting squarely on the bottom of the arm. Fasten the arm to the tube with u-bolt and saddle supplied. Torque to 10 ft lbs.

Install upper arm – Loosely install upper arm near top of tube with supplied u-bolt and saddle *hand tighten* only.

Mount swivel casting – After determining the approximate desired location, taking care to keep the slot in the middle of casting attach swivel to extruded pole with u-bolts and saddles *hand tighten* only.

Install signal head – Place signal head on lower arm with mounting studs entering lower end of signal. Place rubber seal over upper arm stud and lower the assembly until stud enters the top of the signal. Assemble the upper and lower retaining washers and nuts *hand tighten* only. Square up the upper arm and tighten the u-bolt and saddle clamp.

Assemble signal and swivel to saddle – Position the assembly on the face of saddle using the cast in boss on the swivel as a locator, bolt the assembly in place with the supplied 3/8" hardware *hand tighten* only.

Adjust signal – Move signal up or down to get the desired height. Follow signal manufacturer's instructions for proper aiming of the signal.

Tighten mounting hardware – After aiming the signal securely tighten all fasteners. 5/16" hardware to be torque to 10 ft lbs, 3/8" hardware to be torqued to 15 ft lbs, 1/2" hardware to be torqued to 20 ft lbs.

Install foam pole seal – After completing wire routing through the extruded pole, firmly seat the foam sealer into the slot in pole. Seal may be cut to facilitate wire exit/entrance into the pole.

Inspection:

Review installation – Verify all hardware is tightened to proper specifications and banding is sufficiently tight to prevent movement.

Signal view – Verify signal is aimed properly, signal may be readjusted by loosening threaded hardware as required. Retighten hardware if adjustments are required.