

SIGN KIT - BAND STYLE

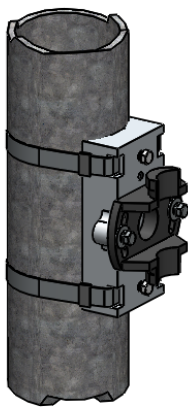

ALTERNATE MOUNTING

Alternate Mounting Method
 For 2" - 3" Pipe
 Remove arm bands, and
 tighten with standard
 banding tool as shown.

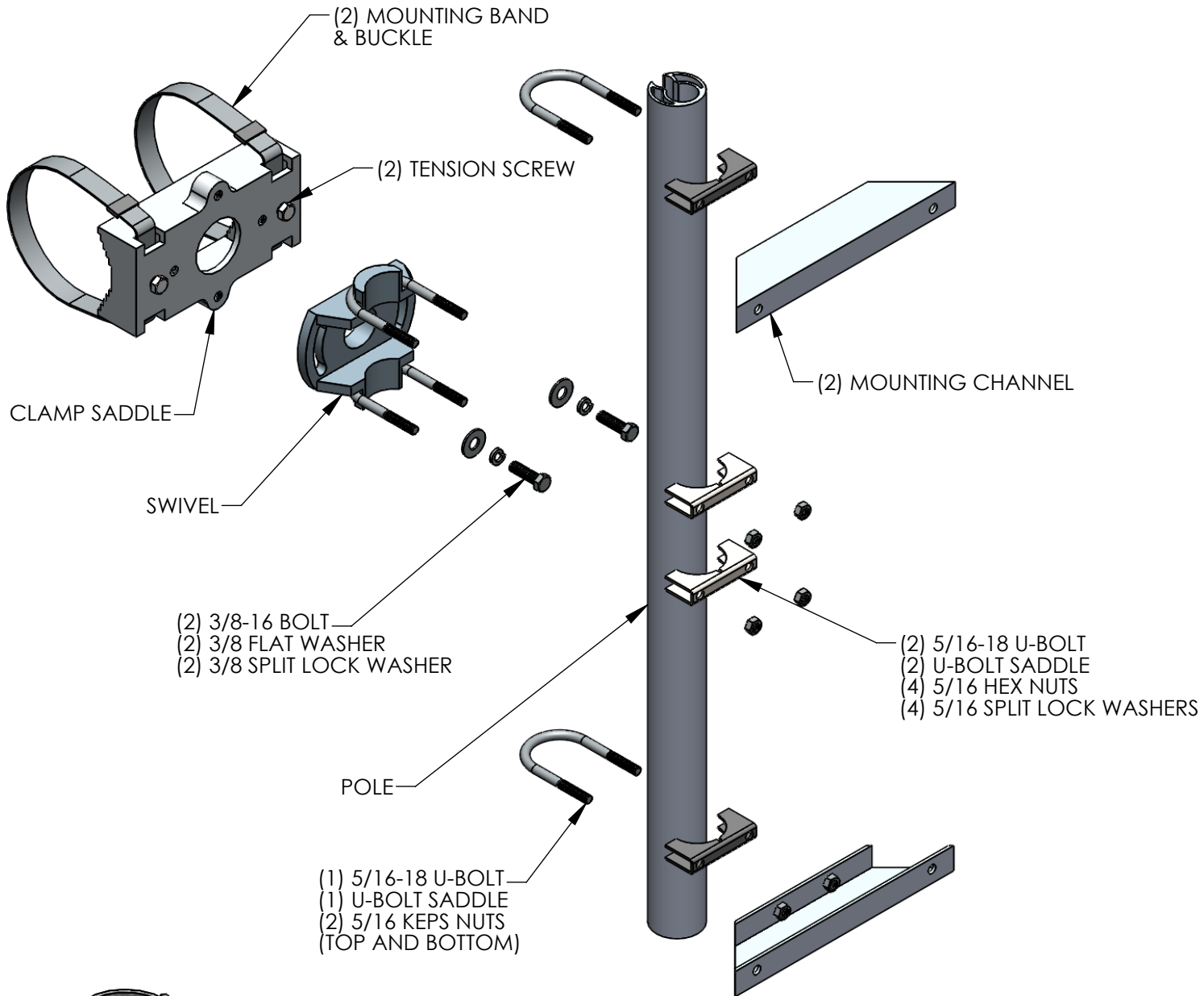
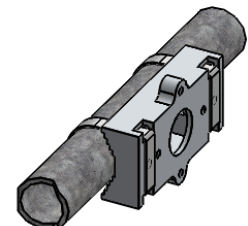

TORQUE CHART	
FASTENER SIZE	TORQUE
5/16"	10 FT-LBS
3/8"	15 FT-LBS
1/2"	15 FT-LBS

Installation Instructions

Sign Mount – Band Style

Preparation:

Read and understand these instructions prior to beginning.

Review installation instructions provided by sign manufacturer. Verify mounting location and method is acceptable.

Check parts against the installation drawing accompanying these instructions, verify all necessary components are present and undamaged.

Review tools required to perform the installation, ensure all tools are present and in good working order prior to beginning the installation process.

Safety first! Review and adhere to all applicable work zone safety information to ensure installer safety.

Installation:

Determine mounting location - When determining the mounting location careful thought must be given to ensure access to tensioning components, adjustment screws and electrical connections.

Mount saddle bracket – With bracket in desired position, tighten banding with an approved banding tool (information may be found at www.band-it-idex.com). Tighten until bands prevent clamp weight from repositioning the assembly. Tighten the 2 pressure screws as needed to add additional tension to banding. Banding must be tight enough to ensure mounting bracket does not shift or slip under load.

Trim bands – Cut off excess banding material, use caution as trimmed edges of banding may be sharp after trimming.

Install mounting channels – Utilizing hardware supplied by sign manufacturer, attach mounting channels to back of sign with long flange of channels contacting sign. Additional holes may be added to channel flange as required.

Install extrusion tube – Loosely install extrusion tube to mounting channels with supplied u-bolts and saddles *hand tighten* only.

Mount swivel casting – After determining the approximate desired location, taking care to keep the slot in the middle of casting attach swivel to extruded pole with u-bolts and saddles *hand tighten* only.

Assemble sign – Position the assembly on the face of saddle using the cast in boss on the swivel as a locator, bolt the assembly in place with the supplied 3/8" hardware *hand tighten* only.

Adjust sign – Move sign along length of extrusion tube to desired location. Care should be taken to keep swivel as close to center of extrusion tube as possible.

Tighten mounting hardware – After adjusting the sign securely tighten all fasteners. 5/16" hardware to be torque to 10 ft lbs, 3/8" hardware to be torqued to 15 ft lbs, 1/2" hardware to be torqued to 20 ft lbs.

Inspection:

Review installation – Verify all hardware is tightened to proper specifications and banding is sufficiently tight to prevent movement.

Sign view – Verify sign is positioned properly, sign may be readjusted by loosening threaded hardware as required. Retighten hardware if adjustments are required.