

ALUMINUM CHANNEL

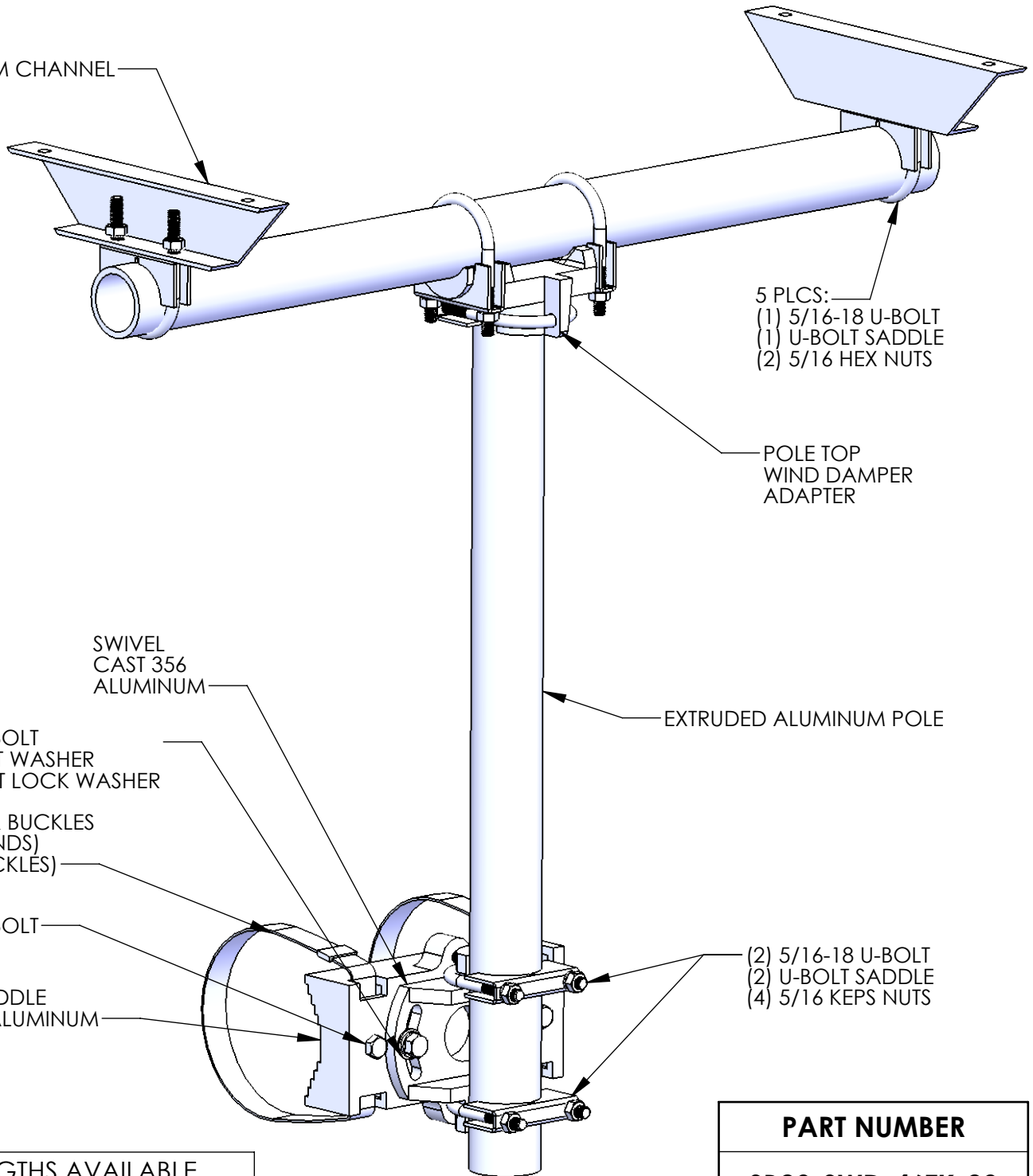

5 PLCS:
 (1) 5/16-18 U-BOLT
 (1) U-BOLT SADDLE
 (2) 5/16 HEX NUTS

POLE TOP
 WIND DAMPER
 ADAPTER

EXTRUDED ALUMINUM POLE

SWIVEL
 CAST 356
 ALUMINUM

(2) 3/8-16 BOLT
 (2) 3/8 FLAT WASHER
 (2) 3/8 SPLIT LOCK WASHER

(2) BAND & BUCKLES
 304 SS (BANDS)
 316 SS (BUCKLES)

(2) 3/8-16 BOLT

CLAMP SADDLE
 CAST 356 ALUMINUM

(2) 5/16-18 U-BOLT
 (2) U-BOLT SADDLE
 (4) 5/16 KEPS NUTS

POLE LENGTHS AVAILABLE

18", 24", 37", 46", 60"

CHANNEL LENGTHS AVAILABLE

8", 14", 23.5"

BAND LENGTH	MAST ARM DIA.
29"	2" - 7"
42"	8" - 11"
59"	12" - 17"

29"

2" - 7"

42"

8" - 11"

59"

12" - 17"

NOTES:

1. YELLOW ZINC DICHROMATE PLATED FASTENERS, STAINLESS STEEL HARDWARE AVAILABLE.
2. AVAILABLE WITH CABLE STYLE CLAMP.

PART NUMBER

SB29-SWD-46TK-23

BAND LENGTH
 TUBE LENGTH
 CHANNEL LENGTH

THE INFORMATION CONTAINED IN THIS DRAWING IS THE SOLE PROPERTY OF SKYBRACKET. ANY REPRODUCTION IN PART OR WHOLE WITHOUT THE WRITTEN PERMISSION OF SKYBRACKET IS PROHIBITED.

SKYBRACKET
 MAST ARM MOUNTING HARDWARE

TITLE
**WIND DAMPER
 (BAND CLAMP)**

APPROVALS	BY	DATE
DRAWN	TRC	7/19/16
SALES		
ENGINEERING		

SIZE	DWG. NO.	REV.
A	SB29-SWD-46TK-23	A

DO NOT SCALE DRAWING

SCALE: NTS | CAD FILE: SB29-SWD-46TK-23

SHEET 1 OF 1