

ARTICULATING BAND STYLE - CLAMP KIT

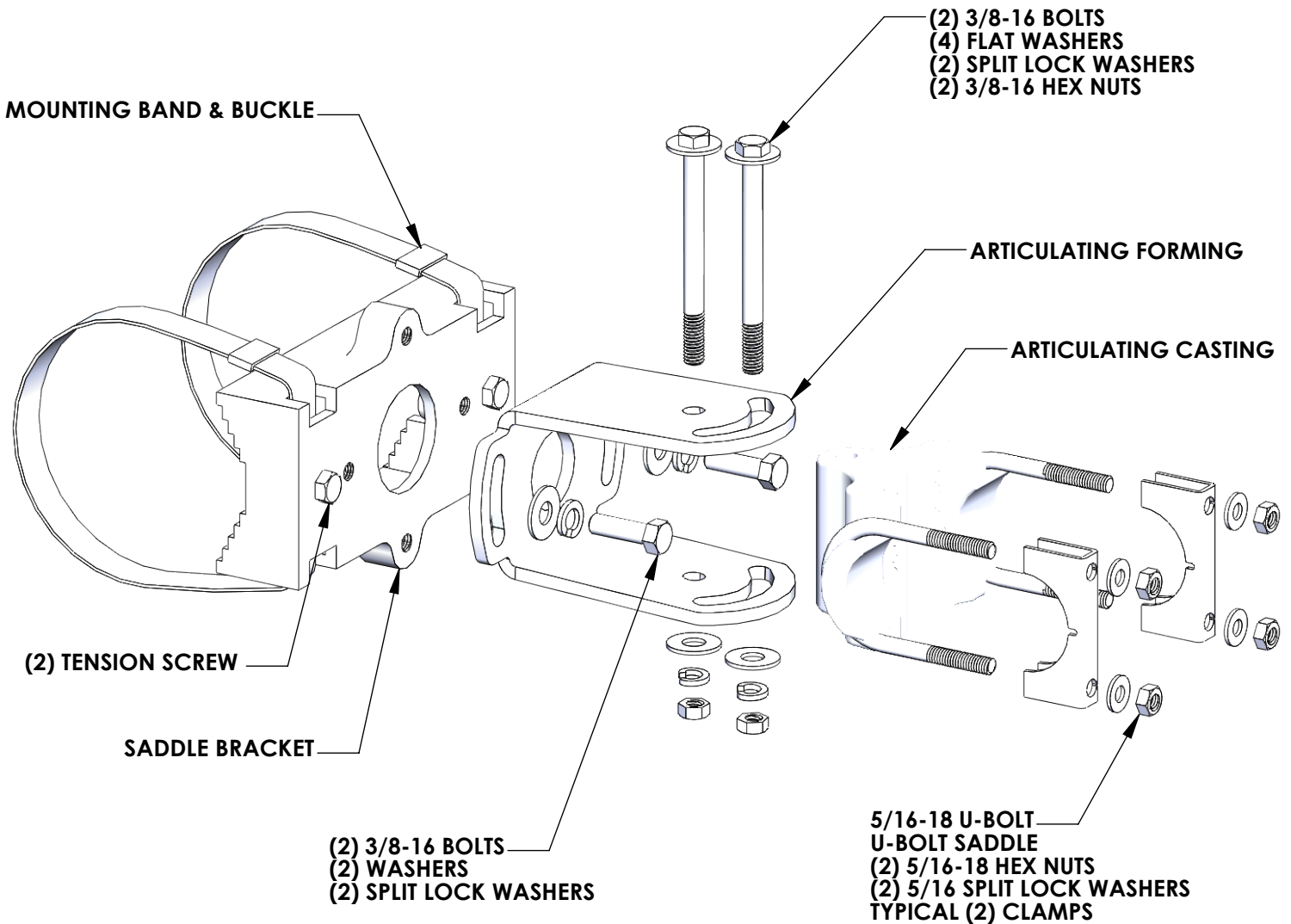

TORQUE CHART

FASTENER SIZE	TORQUE
5/16"	10 FT-LBS
3/8"	15 FT-LBS
1/2"	15 FT-LBS

Installation Instructions

Articulating Band Style Clamp

Preparation:

Read and understand these instructions prior to beginning.

Review installation instructions provided by signal manufacturer. Verify mounting location and method is acceptable.

Check parts against the installation drawing accompanying these instructions, verify all necessary components are present and undamaged.

Review tools required to perform the installation, ensure all tools are present and in good working order prior to beginning the installation process.

Safety first! Review and adhere to all applicable work zone safety information to ensure installer safety.

Installation:

Determine mounting location - When determining the mounting location careful thought must be given to ensure access to tensioning components, adjustment screws and electrical connections.

Mount saddle bracket – With bracket in desired position, tighten banding with an approved banding tool (information may be found at www.band-it-idex.com). Tighten until bands prevent clamp weight from repositioning the assembly. Tighten the 2 pressure screws as needed to add additional tension to banding. Banding must be tight enough to ensure mounting bracket does not shift or slip under load.

Trim bands – Cut off excess banding material, use caution as trimmed edges of banding may be sharp after trimming.

Mount articulating forming – Position forming on saddle face as shown, bolt in place with supplied 3/8" hardware *hand tighten* only.

Mount articulating casting – considering the desired finished location of the product being installed, determine approximately where the center of the clamp would be located. Install the articulating casting to the Extrusion tube with u-bolts and saddles *hand tighten* only.

Assemble product to saddle – Position the assembly from previous step between legs of formed part. Bolt the assembly in place with the supplied 3/8" hardware *hand tighten* only.

Tighten mounting hardware – After aiming the signal securely tighten all fasteners. 5/16" hardware to be torqued to 10 ft lbs, 3/8" hardware to be torqued to 15 ft lbs, 1/2" hardware to be torqued to 20 ft lbs.

Inspection:

Review installation – Verify all hardware is tightened to proper specifications.