

- (2) 3/8-16 BOLT
- (2) 3/8 FLAT WASHER
- (2) 3/8 SPLIT LOCK WASHER

- (2) BAND & BUCKLES
- 304 SS (BANDS)
- 316 SS (BUCKLES)

CLAMP SADDLE  
CAST 356 ALUMINUM

PATTERN ADAPTER

- (2) 3/8-16 BOLT

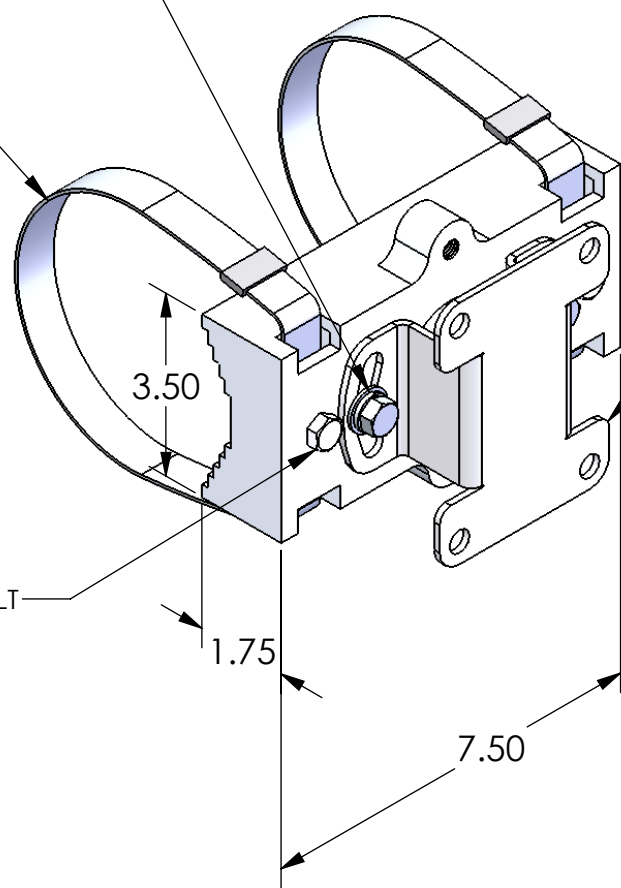

**PART NUMBER**

**SS-SB29-ISM**

BAND LENGTH

BAND LENGTH	MAST ARM DIA.
29"	2" - 7"
42"	8" - 11"
59"	12" - 17"

**NOTES:**

1. STAINLESS STEEL FASTENERS

THE INFORMATION CONTAINED IN THIS DRAWING IS THE SOLE PROPERTY OF SKYBRACKET. ANY REPRODUCTION IN PART OR WHOLE WITHOUT THE WRITTEN PERMISSION OF SKYBRACKET IS PROHIBITED.



TITLE		KIT, ILLUMINATED SIGN BAND CLAMP	
SIZE	DWG. NO.	REV.	
A	SS-SB29-ISM	A	
DO NOT SCALE DRAWING		SCALE: NTS   CAD FILE: SS-SB29-ISM	SHEET 1 OF 1