

BAND STYLE CLAMP MOUNTING

(2) MOUNTING BAND & BUCKLE

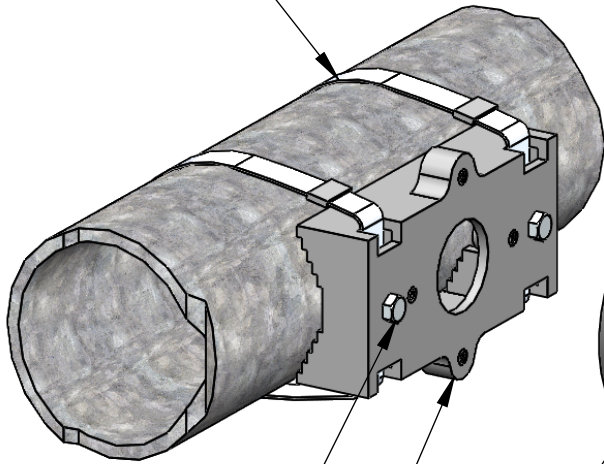

(2) TENSION SCREW

SADDLE BRACKET

SWIVEL

(2) 3/8-16 BOLTS
 (2) WASHERS
 (2) SPLIT LOCK WASHERS

5/16-18 U-BOLT
 U-BOLT SADDLE
 (2) 5/16-18 HEX NUTS
 (2) 5/16 SPLIT LOCK WASHERS
 TYPICAL (2) CLAMPS
 (NOTE: FOR STAINLESS STEEL
 HARDWARE UNIT, A KEPS NUT IS
 USED IN PLACE OF
 LOCKWASHERS AND HEX NUTS)

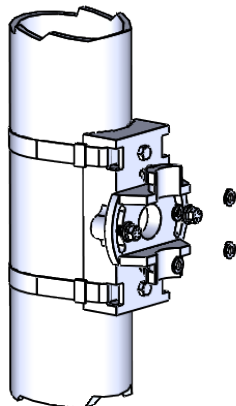

ALTERNATE
 MOUNTING

Alternate Mounting Method
 For 2" - 3" Pipe
 Remove arm bands, and
 tighten with standard
 banding tool as shown.

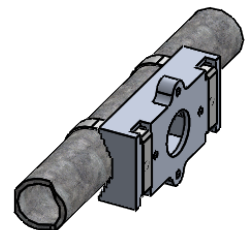

TORQUE CHART

FASTENER SIZE	TORQUE
5/16"	10 FT-LBS
3/8"	15 FT-LBS
1/2"	15 FT-LBS

Installation Instructions

Band Style Clamp

Preparation:

Read and understand these instructions prior to beginning.

Review installation instructions provided by signal manufacturer. Verify mounting location and method is acceptable.

Check parts against the installation drawing accompanying these instructions, verify all necessary components are present and undamaged.

Review tools required to perform the installation, ensure all tools are present and in good working order prior to beginning the installation process.

Safety first! Review and adhere to all applicable work zone safety information to ensure installer safety.

Installation:

Determine mounting location - When determining the mounting location careful thought must be given to ensure access to tensioning components, adjustment screws and electrical connections.

Mount saddle bracket – With bracket in desired position, tighten banding with an approved banding tool (information may be found at www.band-it-idex.com). Tighten until bands prevent clamp weight from repositioning the assembly. Tighten the 2 pressure screws as needed to add additional tension to banding. Banding must be tight enough to ensure mounting bracket does not shift or slip under load.

Trim bands – Cut off excess banding material, use caution as trimmed edges of banding may be sharp after trimming.

Mount swivel casting – considering the desired finished location of the product being installed, determine approximately where the center of the clamp would be located. Install the swivel casting by positioning the center of the alignment boss at the previously determined center point and attach the pole with u-bolts and saddles *hand tighten* only.

Assemble product and swivel to saddle – Position the assembly from previous step on the face of saddle using the cast in boss on the swivel as a locator, bolt the assembly in place with the supplied 3/8" hardware *hand tighten* only.

Tighten mounting hardware – 5/16" hardware to be torqued to 10 ft lbs, 3/8" hardware to be torqued to 15 ft lbs.

Inspection:

Review installation – Verify all hardware is tightened to proper specifications.